

## INSTALLATION AND MAINTENANCE INSTRUCTIONS PNEUMATIC CONTROL VALVE ADCAPURE PV926

### GENERAL

- These instructions must be carefully read before any work involving products supplied by VALSTEAM ADCA ENGINEERING S.A. is undertaken.
- The installation procedure is a critical stage in a life of a valve and care should be taken to avoid damage to the valve or equipment.
- Control valves are designed to give accurate control. They give their maximum performance only when the equipment and piping associated with them is correctly sized and installed in accordance with our recommendations.
- Referring to the name-plate located on pneumatic actuator yoke, check that the product is suitable for the intended use/application as follows:
  - the body material must be compatible with the process fluid
  - compatibility with the pressure and temperature and their maximum and minimum values
- Adcapure control valves are not intended to withstand external stresses that may be induced by any system to which they are fitted. It is the responsibility of the installer to consider these stresses and take adequate precautions to minimise them.

### Note:

- Current regional safety regulations should be take in to account and followed, while doing the installation and maintenance work.
- Handling, installation and maintenance work must be carried out by trained personnel. A supervisor must follow and check all activities.
- For the problems that cannot be solve with the help of this instructions, please contact the supplier or the manufacturer.
- The manufacturer reserves the right to change the design and material of this product without notice.

**CE Marking:** This product has been designed for use on water and other liquids which are in Group 2 of the PED-European Pressure Equipment Directive 97/23/EC and it complies with those requirements.

CE MARKING (PED - European Directive 97/23/EC)	
PN 16	Category
DN1/2" to DN2"	SEP - art. 3, paragraph3



ATTENTION

- If malfunction of any other equipment or system operation failure may result in a dangerous overpressure, over temperature or even vacuum condition, a safety device must be included in the system to prevent such situations.
- At start up, the presence of small particles in the fluid (dirt, scale, weld splatters, etc) may cause an imperfect closure of the seat. If this occurs, proceed to an accurate cleaning.
- Do not touch the equipment without appropriate protection during working operation because it may conduct heat if the used fluid is at high temperature.

- Before starting maintenance be sure that the equipment is not pressurized or hot. Even if upstream and downstream isolating valves have been closed care should be taken since fluid under pressure may be trapped between them.
- The equipments must be used within the working temperature and pressure limits laid down for them, otherwise they may fail (refer to nameplate and/or IS- Information Sheet).
- Manual handling of products may present a risk of injury. You are advised to assess the risks taking into account the task, the individual, the load and the working environment.
- Before starting work ensure that you have suitable tools and/or consumables available. Use only genuine ADCA replacement parts.
- Do not remove the nameplate attached to the equipment. Serial number and other useful information is stamped on it.
- Do not apply the valve for oxygen service, if it hasn't been specifically manufacture for that purpose.
- During the assembly work, apply protective measures against dirt.
- The equipment should be carefully handled, to prevent any damage on the machined surfaces.
- Correct installation of the equipment is full responsibility of the contractor
- Valves are designed to be applied in places protected from exposure to weather.
- We recommend special constructions or protective measures for applications on the outside or in adverse environments like corrosion-promoting conditions (sea water, chemical vapors, etc).
- During maintenance or assembly, careful should be taken to avoid painting the valve stem.

### CLEANING AND PACKING

- This equipment is packed by proper machine with a special film used by food industry.
- These equipments are degreased and cleaned ultrasonically.

### TRANSPORT AND STORAGE



ATTENTION

- Handling and lifting of materials should be made with adequate equipments.
- The valves and equipments should be protected from impacts and forces during transportation and storage.
- The manufacturer doesn't assume the responsibility of damaged equipments due to inappropriate handling during the transportation and storage.

### INSTALLATION



ATTENTION

- Account for over pressure conditions, according with the local laws or standards.
- Valve mountings such as actuators, handwheels, hoods must not be used with other purpose than the one they were built for (e.g. climbing aids or as connecting points for lifting gear)
- For the problems that cannot be solve with the help of this instructions, please contact the supplier or the manufacturer.



### Installation area requirements:

- The installation area should have easy access and provide enough space for maintenance and removing operations.
- The pipework before and after the control valve, must be sized in order to avoid that the max flow speed recommended, for the fluid in question, is exceeded.
- In order to allow installation and maintenance work without emptying the system, stop valves should be installed upstream and downstream of the control valve.
- **If the system cannot be stopped for maintenance it is recommended that isolating valves are installed upstream and downstream of the control valve together with a by-pass manual regulating valve. The process can be then controlled manually during the control valve maintenance. The by-pass must be kept close during the normal operation.**
- To control the pressure, manometers shall be installed upstream and downstream of the valve, (if applicable).
- When a valve with pneumatic actuator is installed on the outside, a special care should be taken to avoid water and other materials suction by the vent hole of the actuator, into the spring housing.

### Procedure:

- Prior to install check that the product is suitable for the intended application: materials and pressure/temperature ratings.
- Before installing remove plastic covers placed on flanges or connection ends. The equipment has an arrow or Inlet/Outlet designations. Be sure that it will be installed on the appropriate direction.
- Take care with jointing material to ensure that none may be permitted to block or enter the valve.
- In case of using Teflon tape (for screwed connections), avoid rolling it till the edge, because it can get cut and migrate to the valve interior, blocking or causing a defective sealing.
- Control valves are recommended to be fitted with the centre line of the valve in a vertical position to ensure that the best results are obtained.
- The valve is designed for sanitary service and it is assumed that the fluid is clean and filtrated. If not, a protection strainer should be used upstream of the valve.
- Do not over-tighten clamps because that can damage the gasket.
- External stresses that may be induced by the system due to pipe expansion, etc, can affect this product. The necessary precautions are recommended during the systems design and equipment assembly.
- The control valve pipework should be properly supported and free from strain and it should not be subjected to undue surges of pressure. For steam installations we strongly recommend that the control valve is positioned where condensation is unable to collect or that, alternatively, separators and steam traps are fitted so that the pipework drains correctly. The start-up condition should be considered.
- The pneumatic actuator is provided of two 1/4"NPT connections, one of these has a silencer. Connect the air to the free 1/4" connection. The inlet air must be dry, oil and water free and it's pressure would not exceed 3,5 bar (50 psi). The suitable control signal is displayed on the name-plate fixed on the valve yoke. If the valve is provided with positioner see also the Installation and Maintenance Instruction IMI PE986.10 and IMI PP981.10.
- Control valves can be supplied with different kind of actuators, positioners, converters, etc. All these components have different limiting conditions which are specified on the nameplates and catalogues and they must be respected. Positioners, electric actuators and other equipment have their own installation instructions.

## START UP



### ATTENTION

- Current regional safety regulations should be taken into account and followed.
- Protective insulation and warning notice may be required.
- Until the start up of an existing or a new plant, the following must be checked:
  - All works are completed.
  - The valve is correctly installed.
  - All the necessary safety devices have been installed.
- **At start up, the presence of small particles in the fluid (dirt, scale, weld splatters, joint particles, remains of Teflon tape, etc) may cause an imperfect closure of the seat. If this occurs, proceed to an accurate cleaning.**
- **Protection varnishes from pipes and flanges, fats, leftover paint, graphite, etc, should also be carefully clean, because they can be dissolved in the fluids (like steam) blocking the regulation elements after the first service stop.**
- During operation high flow noises can be heard.

### Procedure:

1. All stop valves should be closed.
2. Open downstream stop valve.
3. Open slowly the upstream stop valve, in order to avoid water hammer damaging, until the input pressure reaches its limit.
4. The valve is ready.

### Periodical checking:

- 24 hours after the start up, it is recommended to check pipe connections for leaks and retighten the connections if necessary.

## MAINTENANCE

- We recommend the control valves to be serviced as necessary. Control valves should be checked periodically (at least yearly), to verify if they are operating correctly.
- When reassembling make sure that all gasket faces are clean and always use a new gasket.
- Lubrication must be avoided for oxygen service. When it's necessary, only the lubricants recommended by the manufacturer should be used.
- With acetylene gas avoid using copper.
- For further information refer to the relevant IS brochure or consult the factory or distributor.
- Maintenance should proceed as follows:
  1. Isolation valves should be closed and the pressure and temperature must be atmospheric.
  2. Remove sanitary clamps or other type of connection used.
  3. Execute the maintenance work.
  4. Replace and tighten the clamps, (don't forget to substitute the gasket).
  5. Consider the start up conditions.

### Replacement of actuator diaphragm:

In reference to the fig.1 and 2 proceed as follow:

1. Remove the housing screws (14) except the long ones (15) which must be gradually loosen only when the other bolts have been already removed.
2. Remove the housing lid (1) by loosening the plate locknut (13) and removing the disc plate (12) then replace the diaphragm (11).
3. Refit all the items in reverse order.

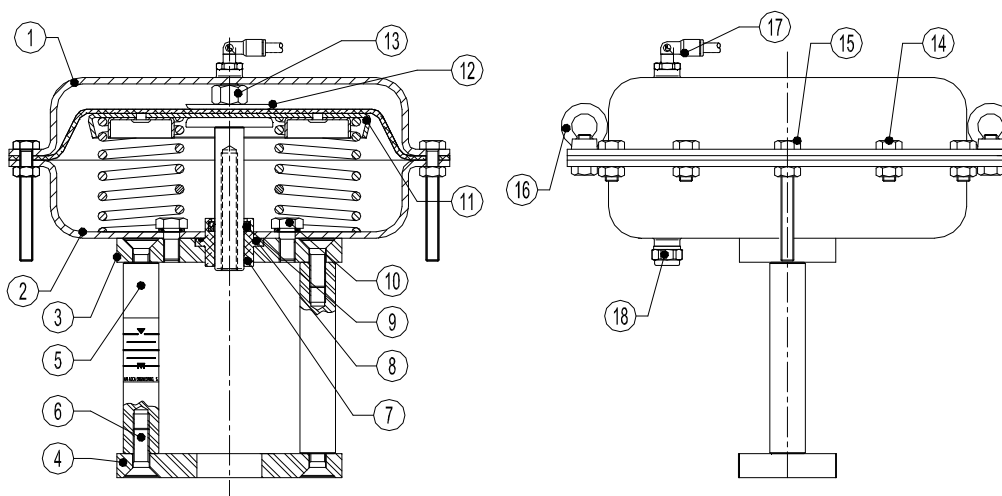

**Fig.1 – Direct action actuator**

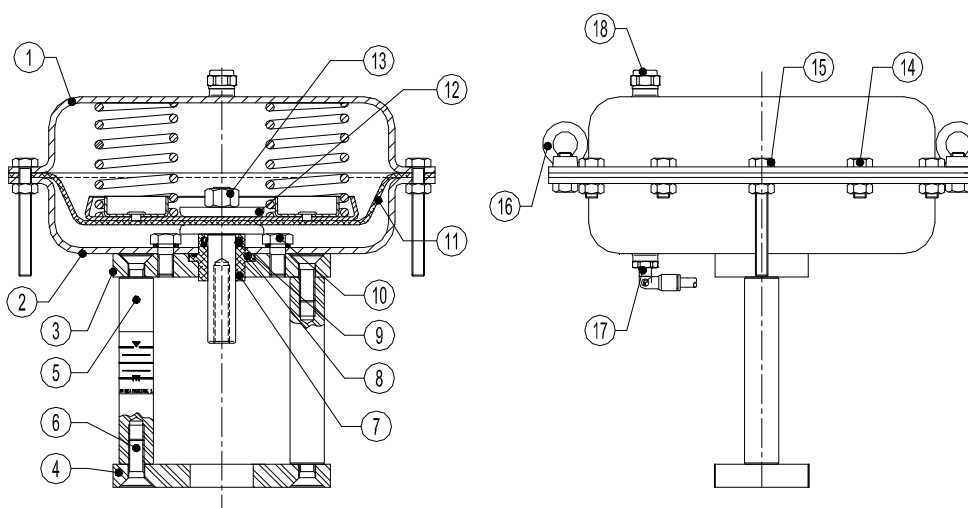

**Fig.2 – Reverse action actuator**

### Removing actuator from valve:

(Please consult the E.IMI-PV16-PV25-PV40)

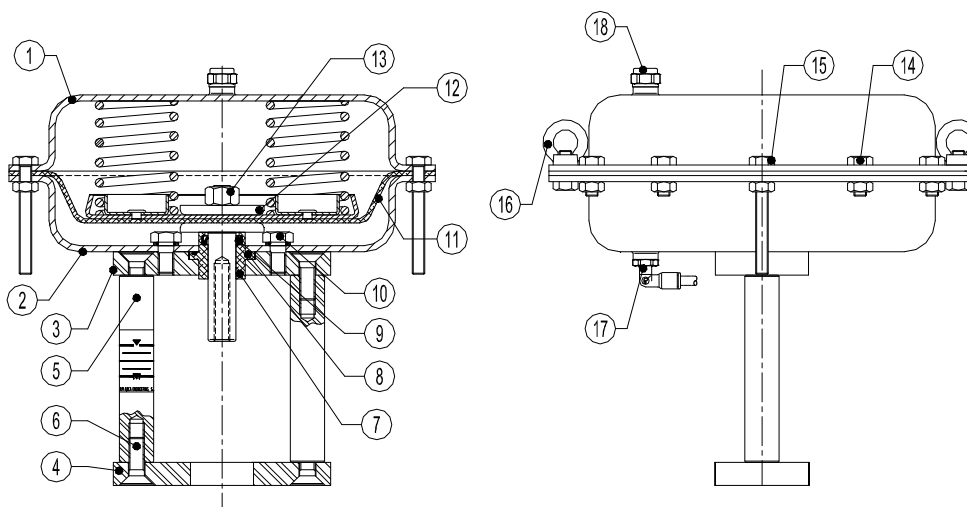
**SPARE PARTS FOR PA SERIES ACTUATORS**

**Fig.8 – PA series actuator**

CODE	DESIGNATION	ACTUATOR TYPE	POS.NR.	QTY.
9.PA205.10	Actuator Diaphragm PA-205	PA205DA and RA	11	1
9.PA280.10	Actuator Diaphragm PA-280	PA280DA and RA	11	1
9.PA340.10	Actuator Diaphragm PA-340	PA340DA and RA	11	1
9.PA435.10	Actuator Diaphragm PA-435	PA435DA and RA	11	1
9.PA205.11	Set of diaphragm seals	PA205-PA435	8,9	1

**SPARE PARTS**

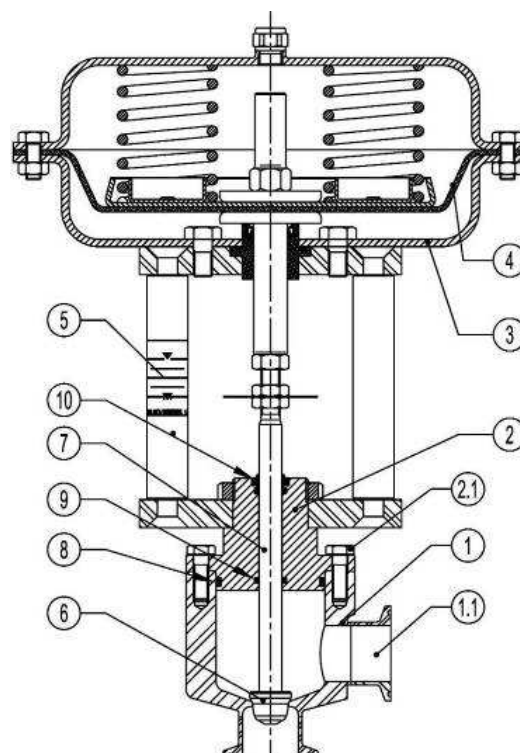
PARTS		
POS.	DESIGNATION	MATERIAL
1	Valve Body	AISI316L / 1.4404
1.1	Ferrule	AISI316L / 1.4404
2	Bonnet	AISI316L / 1.4404
2.1	Bolts	DIN 933 A-2
3	Actuator (Steel)	S235JRG2 / 1.0038
	Actuator (Stainless steel)	AISI304 / 1.4301
4	Diaphragm	NBR 70
5	Yoke (Steel)	C45E / 1.1191
	Yoke (Stainless steel)	AISI304 / 1.4301
6	Valve Seal	PTFE
7	Standard packing	AISI316L / 1.4404
8	O-ring	EPDM
9	O-ring	VITON
10	Seal washer	VITON





## USEFUL NOTES ON VALVE AND PIPE SIZING

- Never size the valve according to the pipe diameter in which it has to be fitted but according to the required actual flow of steam or water. Refer to valve calculation data sheet or consult factory.

## TYPICAL INSTALLATION

- Please consult the available standard assembling drawings or consult the factory for a specific installation drawing.

## PRODUCTS RETURNING



ATTENTION

- Information regarding any hazards and precautions to be considered because of contaminating fluids and residues or mechanical damage that may represent a health, safety or environmental risk, must be provided in writing by the distributors and costumers when returning products to Valsteam ADCA engineering.
- Health and safety data sheets regarding substances identified as hazardous or potentially hazardous must be provided with the information mention above.



ATTENTION

- **LOSS OF WARRANRY:** Total or partial disregard of above instructions involves loss of any right to warranty.